

Mounting advice

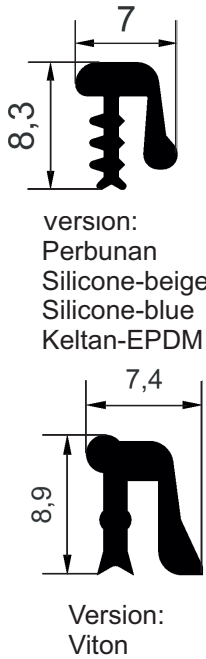

for connecting 2 mm to 1.5 mm thick pipe components  
For 3 mm thick pipe components, the use of U-shaped seals made of NBR or silicone is recommended for a 2 mm pipework system

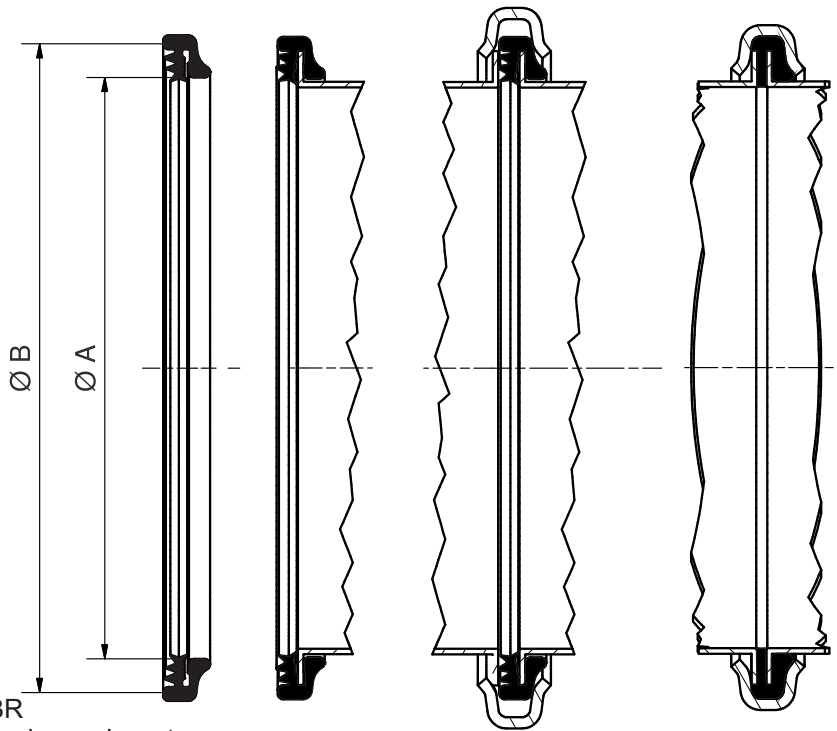

Pipe		Ø 80	Ø 100	Ø 120	Ø 140	Ø 150
Article-no.	Perbunan-NBR-grey white	100869527	101069527	101269527	101469527	101569527
	Silicone-Si-beige	1008795209	1010795209	1012795209	1014795209	1015795209
	Silicone-Si-blue	10087952091	10107952091	10127952091	10147952091	10157952091
	Keltan-EPDM-black	1008895259	1010895259	1012895259	1014895259	1015895259
	Viton-FKM-red	100893869	101093869	101293869	101493869	101593869
Ø A		81	103	123	139	153
Ø B		93	115	135	151	165
Weight in kg		0,02	0,03	0,03	0,04	0,04
Pipe		Ø 175	Ø 200	Ø 224	Ø 250	Ø 280
Article-no.	Perbunan-NBR-grey white	101769527	102069527	102269527	102569527	102869527
	Silicone-Si-beige	1017795209	1020795209	1022795209	1025795209	1028795209
	Silicone-Si-blue	10177952091	10207952091	10227952091	10257952091	10287952091
	Keltan-EPDM-black	1017895259	1020895259	1022895259	1025895259	1028895259
	Viton-FKM-red	101793869	102093869	102293869	102593869	102893869
Ø A		178	203	223	253	280
Ø B		190	215	235	265	292
Weight in kg		0,04	0,05	0,05	0,06	0,06
Pipe		Ø 300	Ø 315	Ø 350	Ø 400	Ø
Article-no.	Perbunan-NBR-grey white	103069527	103169527	103569527	104069527	-
	Silicone-Si-beige	1030795209	1031795209	1035795209	1040795209	-
	Silicone-Si-blue	10307952091	10317952091	10357952091	10407952091	-
	Keltan-EPDM-black	1030895259	1031895259	1035895259	1040895259	-
	Viton-FKM-red	103093869	103193869	103593869	104093869	-
Ø A		303	315	353	403	-
Ø B		315	327	365	415	-
Weight in kg		0,07	0,07	0,08	0,09	-

Denomination:

**U-shaped seals for 2mm pipework system**

Date: 04/20

Datasheet-no. 2/3

Rev. 0